

Owner #	SITE ADDRESS	USE	Owner #	SITE ADDRESS	USE	Owner #	SITE ADDRESS	USE	Owner #	SITE ADDRESS	USE
1	602 W 216TH ST	Residential - 1 Unit	57	21503 MAIN ST	Nursery	113	302 E CARSON ST	Office Building - 5 Units	169	801 E CARSON ST	City Hall(Community Center)
2	606 W 216TH ST	Residential - 1 Unit	58	21507 MAIN ST	Nursery	114	310 E CARSON ST	Office Building - 5 Units	170	801 E CARSON ST	City Hall(Community Center)
3	612 W 216TH ST	Residential - 1 Unit	59	21607 MAIN ST	Retail Center Parking	115	314 E CARSON ST	Residential - 8 Units	171	2 CIVIC PLAZA DR	Civic Center Parking
4	616 W 216TH ST	Residential - 1 Unit	60	21607 MAIN ST	Retail Center Parking	116	330 E CARSON ST	Commercial/Residential - 3 Units	172	2 CIVIC PLAZA DR	Hilton Hotel
5	21817 FIGUEROA ST	Animal Hospital - Parking Lot	61	101 W CARSON ST	Retail Center	117	21818 CARSKILL AVE	Residential - 3 units	173	2 CIVIC PLAZA DR	Civic Center Parking
6	21817 FIGUEROA ST	Animal Hospital	62	101 W CARSON ST	Retail Center	118	336 E CARSON ST	Carson Auto Repair & Business Center	174	1 CIVIC PLAZA DR	Office Building
7	21829 FIGUEROA ST	KFC	63	224 W CARSON ST	Retail Center w/Bar	119	360 CARSON ST	Greenwood Insurance	175	939 E CARSON ST	Office Building
8	621 W CARSON ST	Fast Food Restaurant	64	228 W CARSON ST	Residential - 75 Units	120	21719 MERTUNE AVE	Multi-family Residential	176	939 E CARSON ST	lack in the Box
9	600 W CARSON ST	Vacant Agency Land	65	228 W CARSON ST	Residential - 1 Unit	121	360 CARSON ST	Multi-family Residential	177	1025 E CARSON ST	Vacant Edison Property
10	610 W CARSON ST	Vacant Land/Storage	66	218 W CARSON ST	Park/Gymnasium	122	410 E CARSON ST	Multi-family Residential	178	708 E CARSON ST	Gas Station & Tube
11	21723 FIGUEROA ST	Vacant Land - 1 Unit	67	150 WEST CARSON ST	Senior Housing Complex - 45 Units	123	402 CARSON ST	Samart Federation	179	718 E CARSON ST	El Chorro Restaurant
12	21725 FIGUEROA ST	Vacant Land	68	21735 MAIN ST	Senior Housing Complex - 45 Units	124	420 CARSON ST	Water Billy	180	724 E CARSON ST	Office Building
13	509 W CARSON ST	K's Liquor Store	69	200 - 148 W CARSON ST	Senior Housing Complex - 45 Units	125	440 E CARSON ST	Auto Zone	181	21720 AVALON BLVD	Office Building
14	509 W CARSON ST	Sassony Plaza	70	21701 MAIN ST	Debi Tanco	126	426 E CARSON ST	La Popular Naders	182	21802 AVALON BLVD	Office Center
15	519 W CARSON ST	Office Building	71	23102 MAIN ST	Boys & Girls Club	127	21719 GRACE AVE	Residential - 1 Unit	183	21814 AVALON BLVD	True Value Hardware
16	457 W CARSON ST	Carson Gardens MHP - 97 Units	72	21918 MAIN ST	Lawmover Shop	128	21721 GRACE AVE	Village - 0 Units	184	21828 AVALON BLVD	Carson Christian School
17	457 W CARSON ST	Office Building	73	109 E CARSON ST	Retail Center - 1 Unit	129	519 E CARSON ST	Village - 0 Units	185	750 E CARSON ST	Carson Christian School
18	415 W CARSON ST	Call Inn	74	111 E CARSON ST	Retail Center / El Padio Loco	130	535 E CARSON ST	Village - 0 Units	186	810 E CARSON ST	Medical Office
19	401 W CARSON ST	Nu-Way MHP - 39 Units	75	101 E CARSON ST	Yoshinoya Beer Bowl	131	559 E CARSON ST	Village - 0 Units	187	824 E CARSON ST	Medical Office
20	333 W CARSON ST	The Wheel & Dial Realtor	76	117 E CARSON ST	Foster Freeze	132	545 E CARSON ST	Village - 0 Units	188	860 E CARSON ST	Medical Office
21	317 W CARSON ST	Commercial/Residential 10 Units	77	117 E CARSON ST	LA County Library	133	545 E CARSON ST	Village - 0 Units	189	21739 BONITA ST	Bonita Plaza
22	317 W CARSON ST	Commercial/Residential 10 Units	78	151 E CARSON ST	Carson St Elementary School	134	625 E CARSON ST	Vacant Lot	190	21820 BONITA ST	Residential - 1 Unit
23	307 W CARSON ST	Camino Realty	79	161 E CARSON ST	Manila Sunrise Restaurant	135	625 E CARSON ST	Dental Office	191	21820 BONITA ST	Carnege Middle School
24	301 W CARSON ST	Dentist Office	80	21822 MAIN ST	Vacant Commercial Building	136	21801 AV/ALON BLVD	Dental Office Parking	192	1000 E BONITA ST	Carnege Middle School
25	301 W CARSON ST	Dentist Office	81	21822 MAIN ST	Appliance Store	137	21801 AV/ALON BLVD	Carson Civic Plaza	193	21820 BONITA ST	Carnege Middle School
26	21607 MONETA AVE	Kids World Preschool	82	21806 MAIN ST	Furniture Store	138	655 E CARSON ST	Church			
27	21607 MONETA AVE	Kids World Preschool	83	21800 MAIN ST	Alberstons	139	21821 AV/ALON BLVD	Medical Offices			
28	21704 FIGUEROA ST	Vacant Agency Property	84	21726 CARSON ST	Retail Center	140	21501 AV/ALON BLVD	Bel Aire MHP - 44 Units			
29	21714 FIGUEROA ST	Residential - 2 Units	85	162 E CARSON ST	Bank of America	141	21425 AV/ALON BLVD	Bel Aire MHP - 37 Units			
30	21718 FIGUEROA ST	Residential - 2 Units	86	164 E CARSON ST	Retail Center	142	21425 AV/ALON BLVD	Don Kott Employee Parking Lot			
31	21718 FIGUEROA ST	Residential - 2 Units	87	180 E CARSON ST	Pacific Center	143	640 - 644 E CARSON ST	Don Kott Employee Parking Lot			
32	21710 FIGUEROA ST	Residential - 1 Unit	88	208 E CARSON ST	Rockview Dairy	144	640 E 213TH ST	Don Kott Employee Parking Lot			
33	21710 FIGUEROA ST	Vacant	89	208 E CARSON ST	Carson Car Wash	145	644 E 213TH ST	Arco Gas Station			
34	526 W CARSON ST	Living Breed Ministry/Church	90	225 E CARSON ST	Retail Center	146	21713 AV/ALON BLVD	Arco Gas Station			
35	522 W CARSON ST	Pacific Business Center	91	225 E CARSON ST	Retail Center	147	21718 GRACE AVE	Grace Square			
36	510 W CARSON ST	Vacant Land	92	261 E CARSON ST	Retail Center	148	500 E CARSON ST	Flamingo Gardens MHP - 39 Units			
37	426 W CARSON ST	Office Building	93	261 E CARSON ST	Retail Center	149	520 E CARSON ST	Flamingo Gardens MHP - 37 Units			
38	426 W CARSON ST	Office Building	94	21710 ORRICK AVE	Residential - 1 Unit	150	534 E CARSON ST	Flamingo Gardens MHP - 0 Units			
39	410 W CARSON ST	Residential - 42 Units	95	216 E CARSON ST	Palm Reading/Residential - 1 Unit	151	616 E CARSON ST	Charlottes House			
40	400 W CARSON ST	Residential - 42 Units	96	224 E CARSON ST	Apostolic Christian Church	152	616 E CARSON ST	Vacant Land			
41	324 W CARSON ST	Samoa Congregational Church	97	230 E CARSON ST	Rose Center	153	616 E CARSON ST	Vacant Land			
42	320 W CARSON ST	Samoa Congregational Church	98	234 E CARSON ST	Lucky China Restaurant	154	550 E CARSON ST	Vacant Land			
43	314 W CARSON ST	PSR Center	99	248 E CARSON ST	Dolores Center	155	616 E CARSON ST	Vacant Land			
44	306 W CARSON ST	Gas Station	100	21713 DELORES ST	Retail Center w/light club, pool hall, auto repair	156	616 E CARSON ST	Vacant Land			
45	21721 MONETA AVE	Residential - 1 Unit	101	305 E CARSON ST	Carson Retirement Center	157	21801 AV/ALON BLVD	Avallon Carson Plaza			
46	21606 MONETA AVE	Residential - 1 Unit	102	345 E CARSON ST	Office Building	158	21316 AV/ALON BLVD	Gas Station			
47	21610 MONETA AVE	Residential - 1 Unit	103	359 E CARSON ST	Office Building	159	21350 AV/ALON BLVD	Post Office			
48	21616 MONETA AVE	Retail Center	104	357 E CARSON ST	Office Building	160	717 E DESFORD ST	Sherris Department			
49	233 W CARSON ST	Dental Office	105	401 E CARSON ST	Vacant Land	161	21350 AV/ALON BLVD	Post Office Parking			
50	227 W CARSON ST	Retail	106	409 E CARSON ST	Nursery	162	21350 AV/ALON BLVD	Post Office Parking			
51	221 W CARSON ST	Law Office	107	409 E CARSON ST	Residential - 5 Units	163	21350 AV/ALON BLVD	Post Office Parking			
52	221 W CARSON ST	Residential - 1 Unit	108	415 E CARSON ST	Vacant Land	164	21350 AV/ALON BLVD	Post Office Parking			
53	213 W CARSON ST	Vacant Land - 2 Units	109	427 E CARSON ST	Vacant Agency Land	165	21350 AV/ALON BLVD	Post Office Parking			
54	137 W CARSON ST	Vacant Land	110	441 E CARSON ST	Retail Center	166	701 E CARSON ST	City Hall and Community Ctr Parking			
55	137 W CARSON ST	Retail Center - Seaford City	111	441 E CARSON ST	Retail Center	167	701 E CARSON ST	City Hall			
56	21523 MAIN ST	Nursery	112	21716 DELORES ST	Residential - 1 Unit	168	701 E CARSON ST	City Hall			

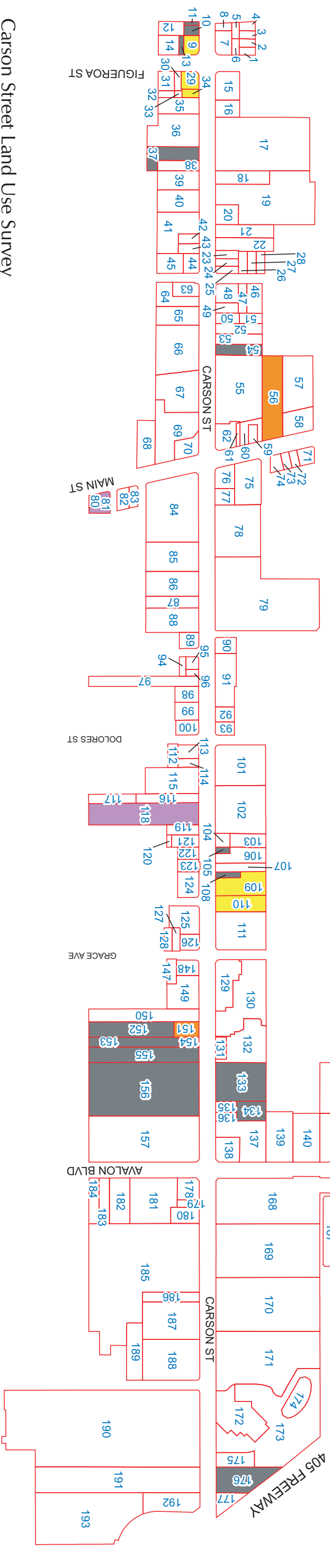

- LEGEND**
- Redevelopment Agency owned land
 - Vacant parcels with no existing buildings
 - Vacant land with existing buildings
 - Underutilized parcels

Carson Street Land Use Survey



Source: City of Carson GIS Department

